



**american
security
equipment
company**

CORPORATE OFFICE & WAREHOUSE
228 East Star of India Lane, Carson, CA 90746
Phone (310) 538-4670 * Fax (310) 538-9932 * (800) 421-1096

EAST COAST OFFICE & WAREHOUSE
30 Chapin Road 1207, Pine Brook, New Jersey 07058
Phone (973) 575- 4433 * Fax (973) 575-5504 * (800) 526-1060
[Http://www.amseco-kai.com](http://www.amseco-kai.com) / e-mail: info@amseco-kai.com

EBP-405A

Door Announcer System

Description

The EBP-405A is an innovative infrared announcer system designed to provide you with a reliable and pleasant announcement of customers entering and exiting your business establishment. The complete kit provides for a quick and easy installation.

A single red LED is provided for fast and easy alignment. A pleasant chime welcomes your customers and warns you of the presence of incoming visitors. The single detection technology utilized on the design eliminates the need for wiring a separate transmitter by using a reflector.

The EBP-405A infrared receiver is virtually unaffected by room light, indirect sunlight, or other bright light sources. White clothing is also accurately detected by the infrared sensor, where other less sophisticated announcers have reflection problems.

Another helpful feature is the 2-chime capability. It allows the user to install chimes in two different areas on the premises, important in securing one employee businesses.

Features

- 35ft. detection range across doorway.
- Pleasant Entry/Exit chime sound.
- Low power consumption.
- Two chimes capability (CM-3A).

Application



EBP-405A Complete Kit

Complete Kit Includes

- [1] Infrared Beam Sensor.
- [1] Mechanical Chime (CM-3A).
- [1] Reflector.
- [1] Filter mask.
- [1] Power transformer (XF-1220 UL/CSA Approved).
- [2] Mounting brackets.
- [1] 6-foot power cord with ON/OFF switch.
- [1] 26ft. 2/conductor chime wire (AWG #22).
- [1] Wing bolt to secure main unit.
- [4] Screws for mounting chime.
- [4] Screws for securing mounting brackets.

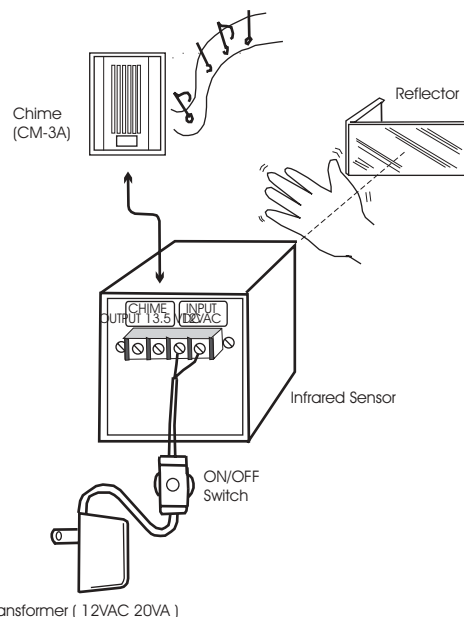

Ideal for strip malls, office buildings, liquor stores, large retail establishments, warehouses, parking structures, donut shops, medical offices, drive-thru fast food restaurants or just to monitor In and Out traffic.

EBP-405A Wiring Diagram

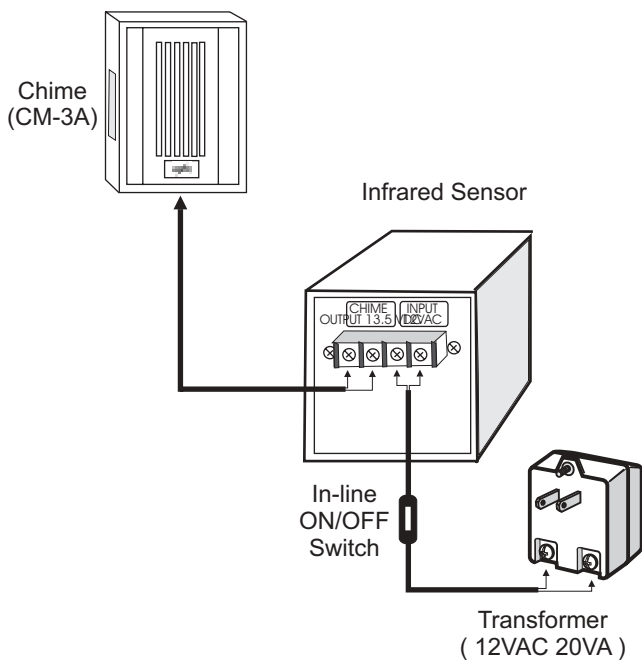

Dimensions: inch (mm)

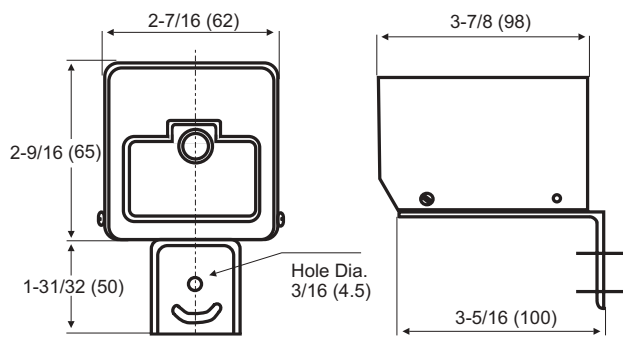

Specifications:

Model Number	EBP-405A	CM-3A
Description	Infrared beam sensor	Mechanical chime
Detection method	Active infrared	--
Detection range	35 feet	--
Chime sound output	--	82 decibels
Power consumption:	Standby 70mA	1.13A
Installation	Indoor	Indoor
Power Input	9 16VAC	13.5VDC
Power output	13.5VDC	--
Response time	50msec.	--
Operating temperature range	14 F ~ 140 F	(-10 C ~ +60 C)

Wiring distance between unit and chime.

- Standard one (1) chime with furnished AWG #22 wire.

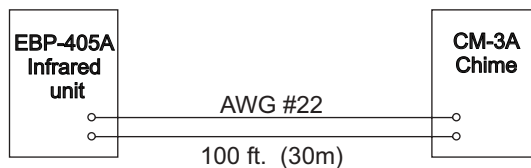

Wire Size	Max. distance
AWG #22	100ft (30m)
AWG #20	164ft (50m)
AWG #18	262ft (80m)

- Two (2) chime installation.

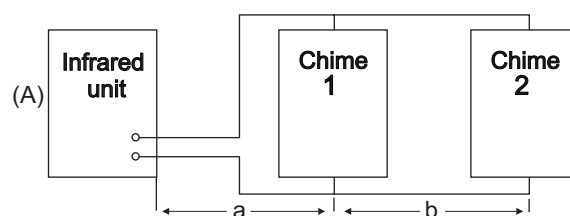

a + b = distance	
AWG #22	68ft (20m)
AWG #20	100ft (30m)
AWG #18	164ft (50m)

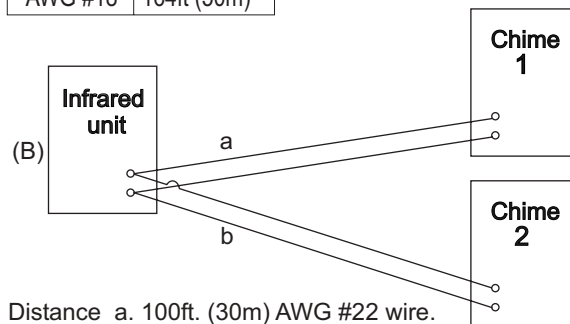

Distance a. 100ft. (30m) AWG #22 wire.

Distance b	Wire gage
100ft. (30m)	AWG #22
164ft. (50m)	AWG #20
262ft. (80m)	AWG #18